



ROCK MILLS
ENTERPRISES



The LifterSM removes manhole covers easily and safely from the comfort of your truck cab.



The LifterSM

- Runs off standard 12 volt battery
- Fits into 2" hitch receiver, disconnects quickly and easily
- Custom hydraulics
 - 5,000 lb. of lift force
 - 7,000 lb. of down pressure
- Weatherproof wireless remote
- Electro-magnet with 8" diameter
 - 5,000 lb. adhesion (metal to metal)
- Camera & Monitor System
 - Color camera with high density
 - Waterproof connections/cable
 - 5.6" diagonal flat screen
 - Heated
 - High Resolution with 307,000 pixels
 - Accepts up to 3 cameras

1 year

money-back guarantee!

Both The LifterSM and The LockingSM Cover include a one year money-back guarantee!

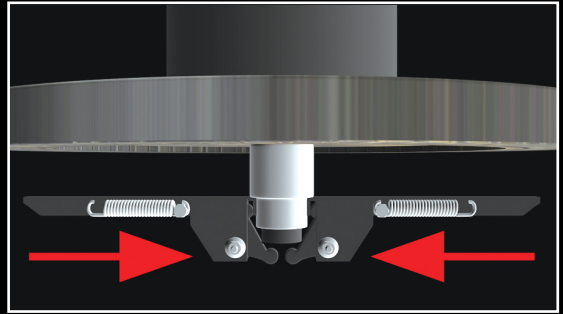

With The LifterSM magnet activated, The LockingSM Cover can safely and easily be unlocked, removed, replaced, or locked.



The LockingSM Cover

- Retractable locking arms
- Arms in extended position lock underneath industry-standard casing
- 500 lb. pressure key mechanism
- Can be purchased new or retro-fitted to existing covers
- Operates only in conjunction with The LifterSM from Rock Mills Enterprises
- Eliminates manhole cover theft and compromising of vulnerable infrastructure

Rock Mills Enterprises

Phone: 1-712-451-6550

Email: sales@rockmillsent.com

Web: www.rockmillsent.com

1007 20th Ave., Rock Valley, Iowa 51247